

# VITA™ LOAD NAVIGATOR™

TECHNICAL DATA

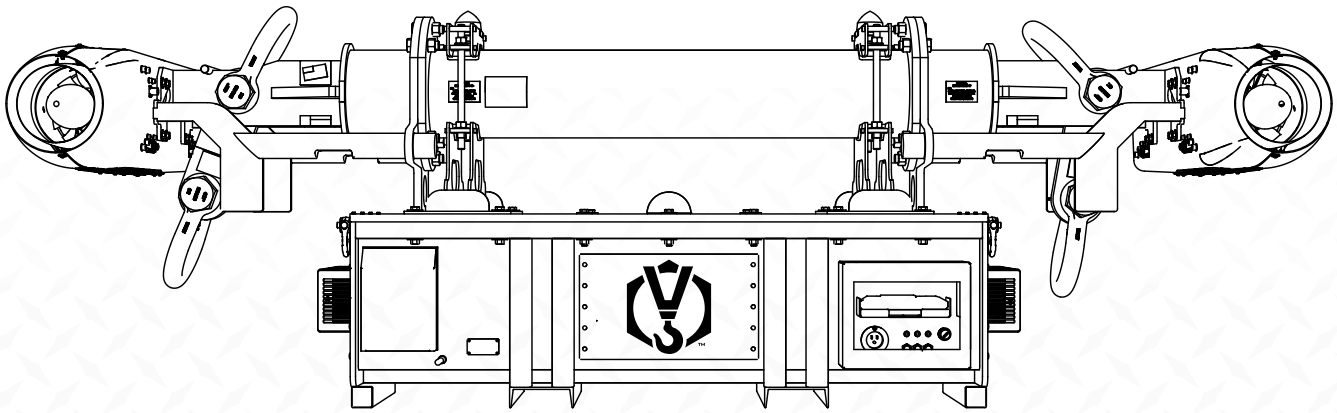

REMOTELY STABILIZE AND  
ORIENT LOADS UNDER  
CRANES

[vitaindustrial.co](http://vitaindustrial.co)

D100194  
v1.3.3

# COMPONENTS

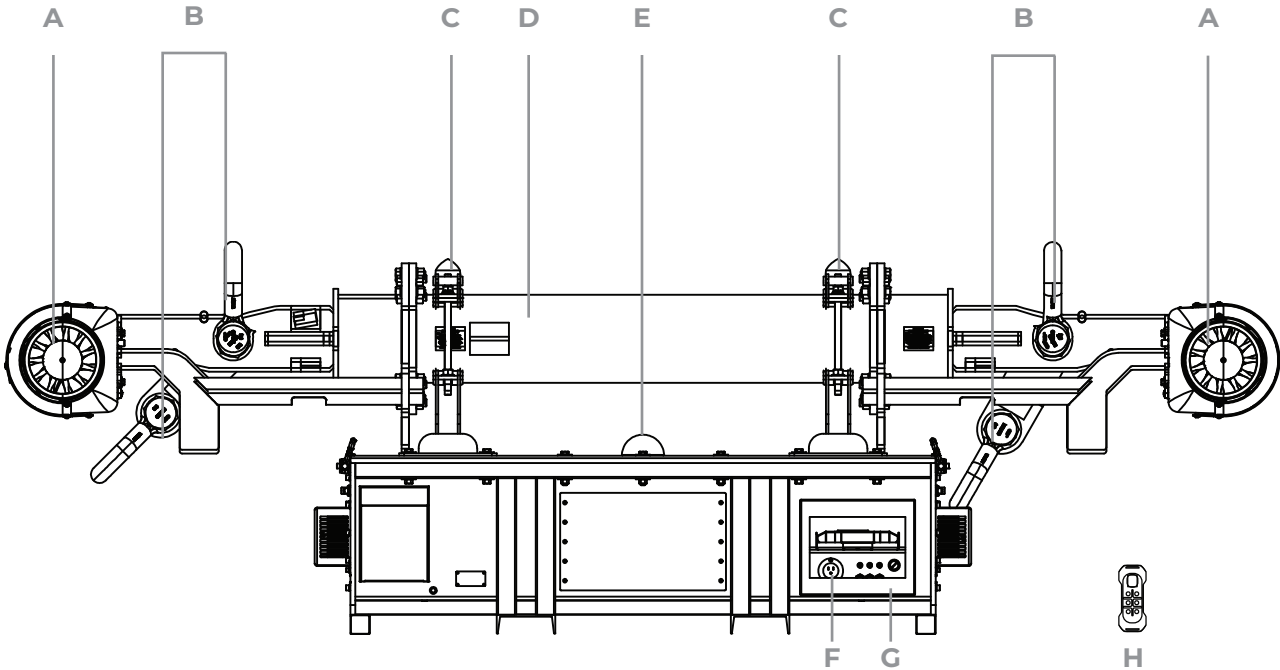

- |          |                                  |          |                              |
|----------|----------------------------------|----------|------------------------------|
| <b>A</b> | Bi-directional propulsion system | <b>E</b> | LTE antenna                  |
| <b>B</b> | Shackles                         | <b>F</b> | Charging port                |
| <b>C</b> | GPS antenna                      | <b>G</b> | IO panel and pendant storage |
| <b>D</b> | Spreader beam                    | <b>H</b> | Control pendant              |

# CHARGING, BATTERIES AND COMMUNICATION

## SYSTEM BATTERIES AND COMMUNICATION

BATTERY	8.6 kWh rechargeable Lithium Iron Phosphate battery
BATTERY LIFE	Up to 12 hours on a single charge, depending on use and environmental conditions
CHARGING	IEC C13 Charging input 100-120V A/C, 1400VA(W) 50/60HZ or 200-240 A/C, 1650VA(W) 50/60HZ
CHARGE TIME	6 to 8 Hours
GPS ANTENNA	L1 band compatibility including: GPS, QZSS, and Galileo
LTE CONNECTIVITY	Global 3G/4G. WiFi available

## PENDANT BATTERIES AND COMMUNICATION

BATTERY	3.7 VDC with Li-ion Battery
BATTERY LIFE	10 hours at 68°F (20°C) ambient temperature
PENDANT RANGE	600ft (182m)
COMMUNICATION	ISM Band: frequency is region-specific
WEIGHT	.84lbs (.381kgs)
DIMENSIONS	8.17in x 3.35in x 1.92in (20.75cm x 8.51cm x 4.88cm)

# STOCK MODELS OVERVIEW

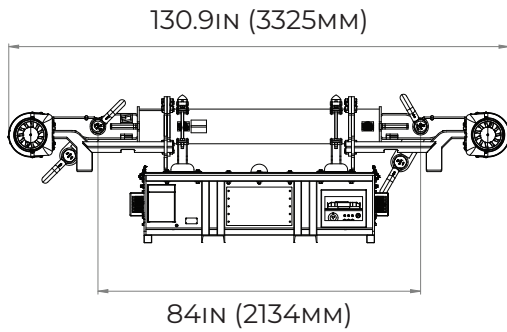

## VLN 40T-7-CA

Weight	1,770 lbs (800 kg)
Nominal Inertia Rating	3,000,000 lb·ft <sup>2</sup> (130,000 kg·m <sup>2</sup> )
Torque	500 ft·lb (678 N·m)

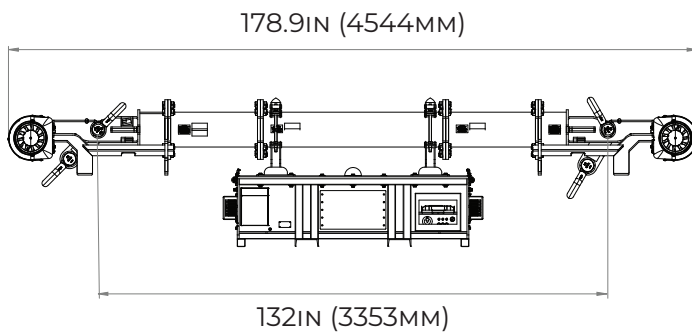

## VLN 40T-11-CA

Weight	2,125 lbs (965 kg)
Nominal Inertia Rating	4,150,000 lb·ft <sup>2</sup> (175,000 kg·m <sup>2</sup> )
Torque	700 ft·lb (949 N·m)

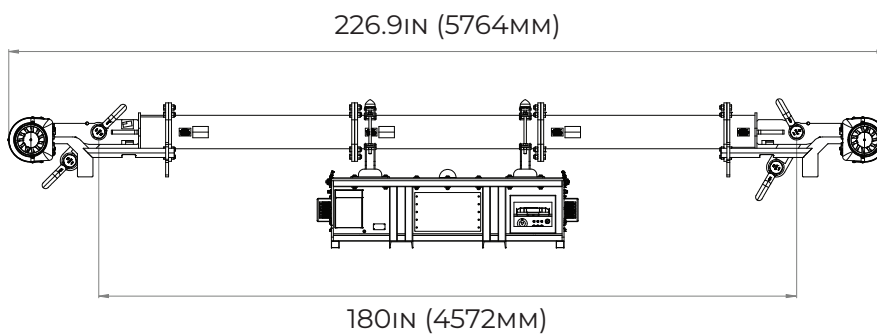

## VLN 40T-15-CA

Weight	2,310 lbs (1,050 kg)
Nominal Inertia Rating	4,700,000 lb·ft <sup>2</sup> (200,000 kg·m <sup>2</sup> )
Torque	800 ft·lb (1085 N·m)

# SPAN VS CAPACITY 40T CONFIGURATIONS

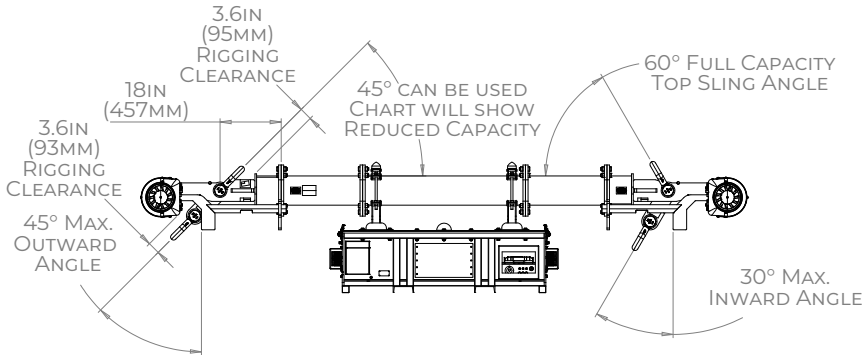

\* 30° INWARD ANGLE ON BOTTOM SHACKLES NOT AVAILABLE FOR VLN 40T-7 CONFIGURATION

## VLN 40T SPAN VS CAPACITY GIVEN:

Max outward lower sling angle: 20° from vertical  
 Max. inward lower sling angle: 10° from vertical

BEAM LENGTH	BASE TO SLING ANGLE		
	45° BSA - MIN TOP	60° BSA - MIN TOP	70° BSA - MIN TOP
7' (2.13m)	32.0 tn (29 mt)	44.1 tn (40 mt)	44.1 tn (40 mt)
11' (3.35m)	27.6 tn (25 mt)	44.1 tn (40 mt)	44.1 tn (40 mt)
15' (4.57m)	23.1 tn (21 mt)	44.1 tn (40 mt)	44.1 tn (40 mt)

## VLN 40T SLING LENGTHS

BEAM LENGTH	BASE TO SLING ANGLE		
	45° - MIN TOP	60° - MIN TOP	70° - MIN TOP
7' (2.13m)	4' (1.21m)	6'1" (1.85m)	9'4" (2.84m)
11' (3.35m)	6'11" (2.11m)	10'1" (3.07m)	15'2" (4.62m)
15' (4.57m)	9'8" (2.95m)	14'1" (4.29m)	21' (6.40m)

## VLN 40T SPAN VS CAPACITY GIVEN:

Outward lower sling angle: 20° to 45° from vertical  
 Inward lower sling angle: 10° to 30° from vertical

BEAM LENGTH	BASE TO SLING ANGLE		
	45° BSA - MIN TOP	60° BSA - MIN TOP	70° BSA - MIN TOP
7' (2.13m)	26.5 tn (24 mt)	36.4 tn (33 mt)	44.1 tn (40 mt)
11' (3.35m)	22.0 tn (20 mt)	32.0 tn (29 mt)	39.6 tn (36 mt)
15' (4.57m)	17.6 tn (16 mt)	27.6 tn (25 mt)	35.3 tn (32 mt)

\*\* mt = metric ton  
 tn = US ton

# INPUT OUTPUT (IO) Box

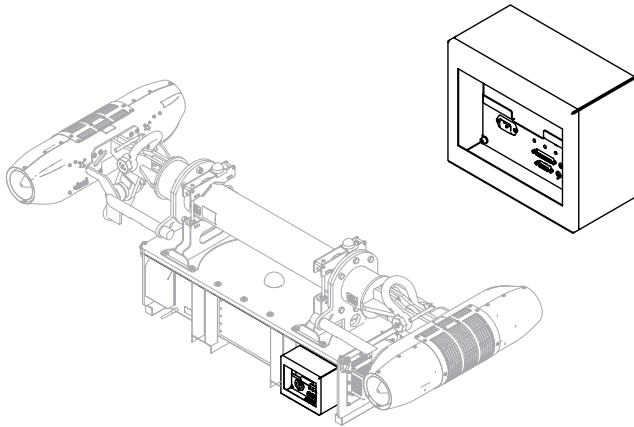

\* The panel IO interfaces may vary depending on region

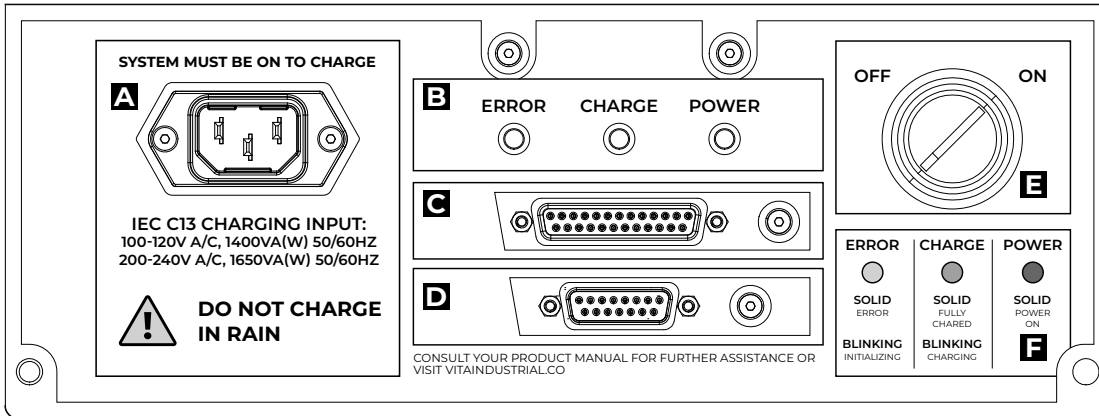

- |          |   |          |   |
|----------|---|----------|---|
| <b>A</b> | Charging Port                           | <b>D</b> | Service Access 2 (Not for customer use) |
| <b>B</b> | System Status LED Indicators            | <b>E</b> | Power toggle                            |
| <b>C</b> | Service Access 1 (Not for customer use) | <b>F</b> | LED Indicator Key                       |

# CAPABILITIES

## DIRECT CONTROL

Manual control allows the user to rotate the load either clockwise (A) or counter clockwise (B). Rotate between 1.5° and 20° per second.

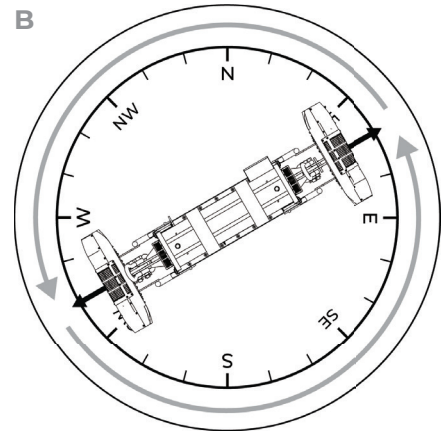
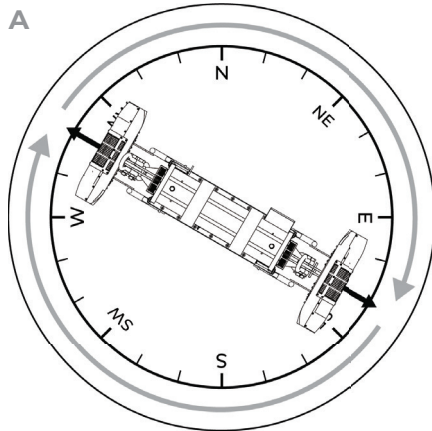

## MEMORY FUNCTION

The user is able to save the orientation of the Navigator at the pick (C) and placement (D) points, and return to either orientation at the push of a button.

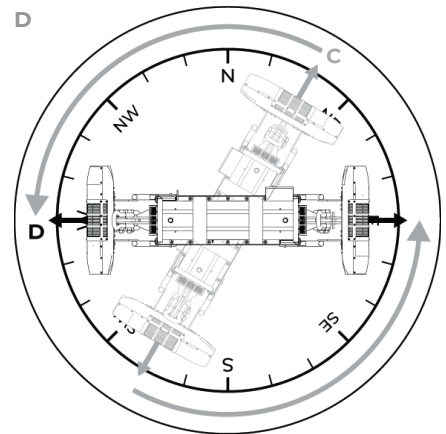
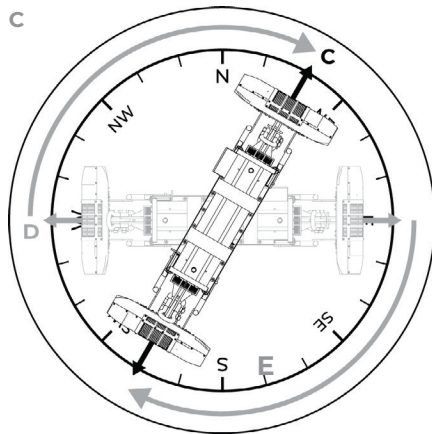

## POSITION HOLD

Position hold keeps the load in an orientation set by the user.

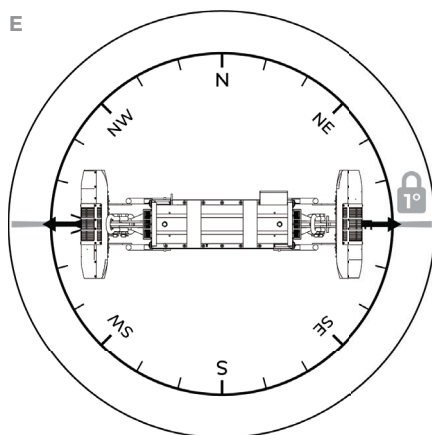

# CONTROL PENDANT

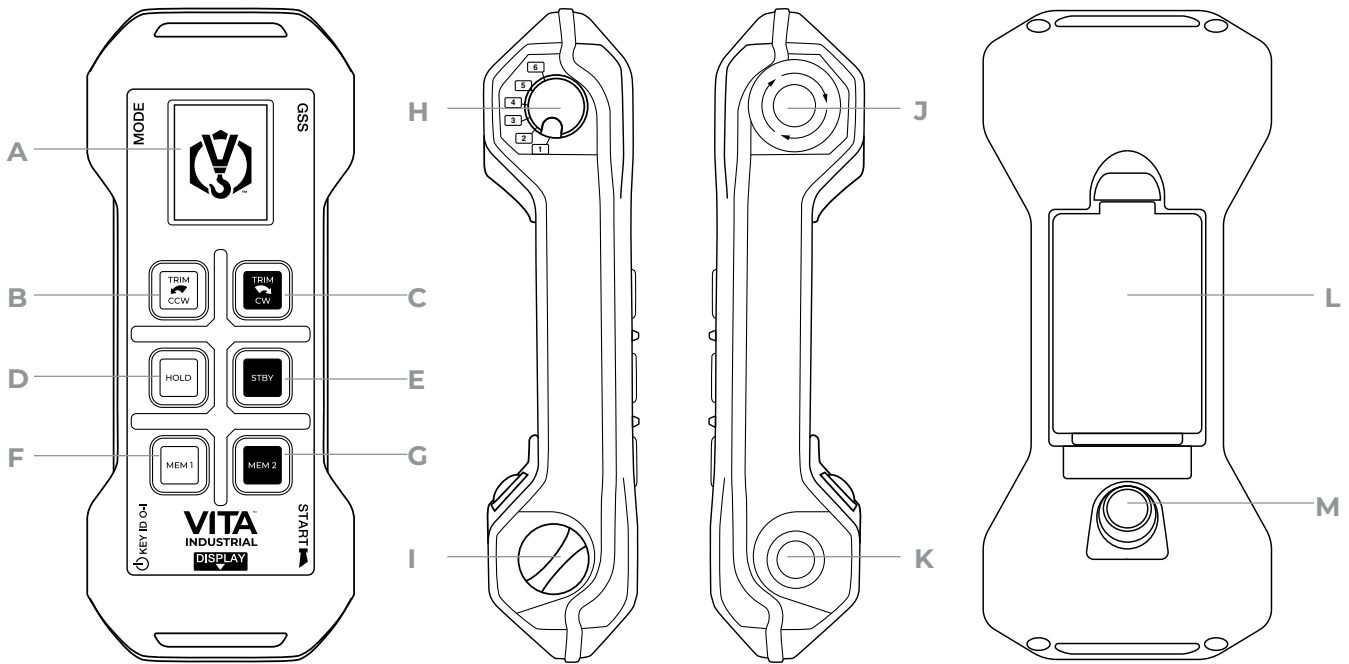

**A** Display screen

**B** Course trim/fine trim  
*Rotates counter clockwise*

**C** Course trim/fine trim  
*Rotates clockwise*

**D** Position control mode  
*Hold current position and/  
or re-orient to new position*

**E** Standby  
*Bi-directional propulsion  
system spins down*

**F** Register/command  
*Memory location 1*

**G** Register/command  
*Memory location 2*

**H** Rotation rate dial  
*Increase/decrease trim  
speed*

**I** RF Key

**J** Emergency stop

**K** Power button

**L** Pendant battery

**M** Cycle between screens



# CONTROL PENDANT DISPLAY SCREEN

## HOME SCREEN

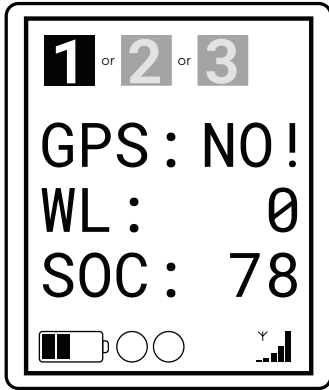

## WORKING SCREEN

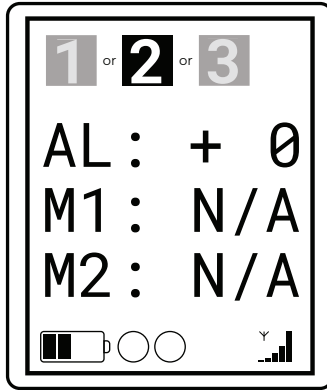

### HOME SCREEN

**GPS** GPS connection status

**WL** Percentage of maximum thrust for the VLN fans (working load)

**SOC** System state of charge (percentage of charge of the VLN battery)

 Pendant battery status

 Signal strength to VLN

 (Green) Pendant connection status  
(Red) Pendant Error status

### WORKING SCREEN

**AL** Difference between the set position and the current position

**M1** Mem 1 heading

**M2** Mem 2 heading

### SYSTEM STATE

**1** Standby

**2** Position Control

**3** User Directed Action

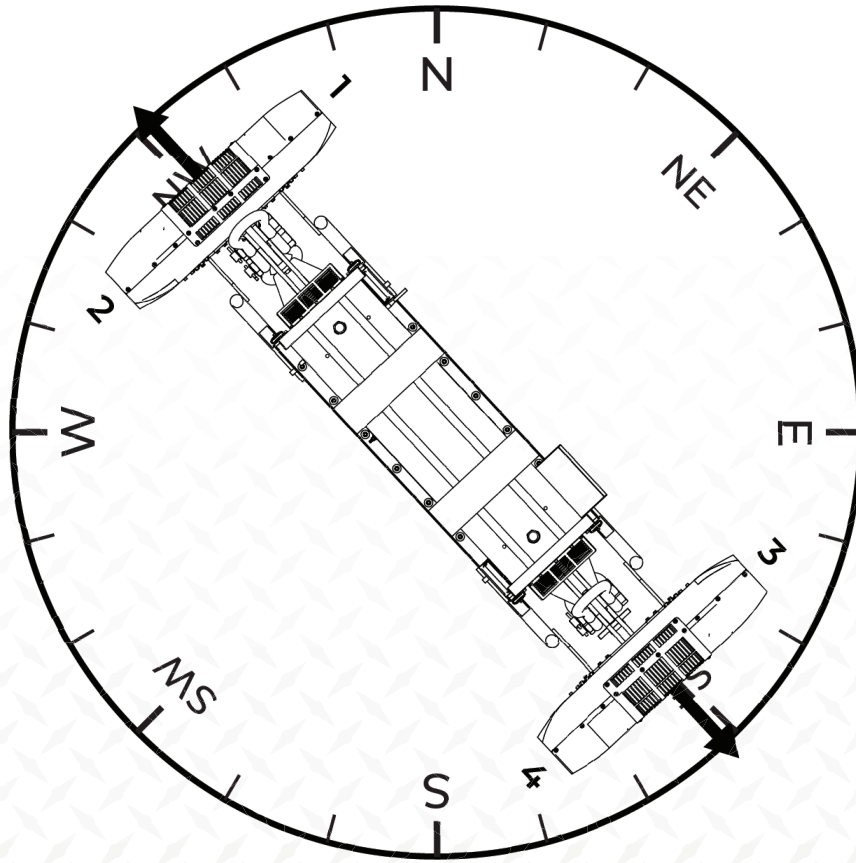

[vitaindustrial.co](http://vitaindustrial.co)

[support@vitatech.co](mailto:support@vitatech.co)